



# Electrolux

## Food Processor Cutter Mixer 2,5 LT - Single Speed

ITEM # \_\_\_\_\_

MODEL # \_\_\_\_\_

NAME # \_\_\_\_\_

SIS # \_\_\_\_\_

AIA # \_\_\_\_\_



Electrolux



603836 (K25Y)

Cutter Mixer 2,5 LT - Single Speed - 220-240V/1/50

### Short Form Specification

Item No. \_\_\_\_\_

Table top cutter. 2,5 litre stainless steel bowl with central feed hole for adding products in mid-cycle. Transparent polycarbonate cover. Smooth blade rotor. Angled blades and conical base of the bowl ensure consistent mixing. No-volt release system prevents accidental starting of the machine. Parts in contact with food are removable and dw safe. Waterproof control buttons. 1 speed rotation: 1500 rpm.

### Main Features

- Direct shaft drive.
- Delivered with:
  - 2,5 liter stainless steel bowl with smooth edge
  - "S" blade included
- Red OFF, green ON and PULSE buttons.
- Magnetic safety system and motor brake. Prevents machine from running when bowl lid swings away from magnetic switch or is open.
- Parts in contact with food are removable and dishwasher safe.
- Pulse function to coarse chopping.
- Productivity suitable for 10-50 meals per service.

### Construction

- Power: 370 watts.
- Speed motor: 1.500 rpm.
- IP55 waterproof control panel.
- All polycarbonate plastic, stainless steel bowl and transparent lid with central hole to add ingredients during the preparations.
- Compact and portable design.

### Included Accessories

- 1 of Smooth blade rotor for 2,5 lt cutter mixer PNC 653146
- 1 of Stainless steel bowl for 2,5 lt cutter mixer PNC 653487
- 1 of Transparent lid for cutters (K25 and Multigreen) PNC 653512

### Optional Accessories

- Microtooth blade rotor for 2,5 lt cutter mixer PNC 650035
- Cutter equipment (stainless steel bowl, lid and rotor) for K25 and Multigreen PNC 653047
- Smooth blade rotor for 2,5 lt cutter mixer PNC 653146
- Stainless steel bowl for 2,5 lt cutter mixer PNC 653487
- Transparent lid for cutters (K25 and Multigreen) PNC 653512

APPROVAL: \_\_\_\_\_

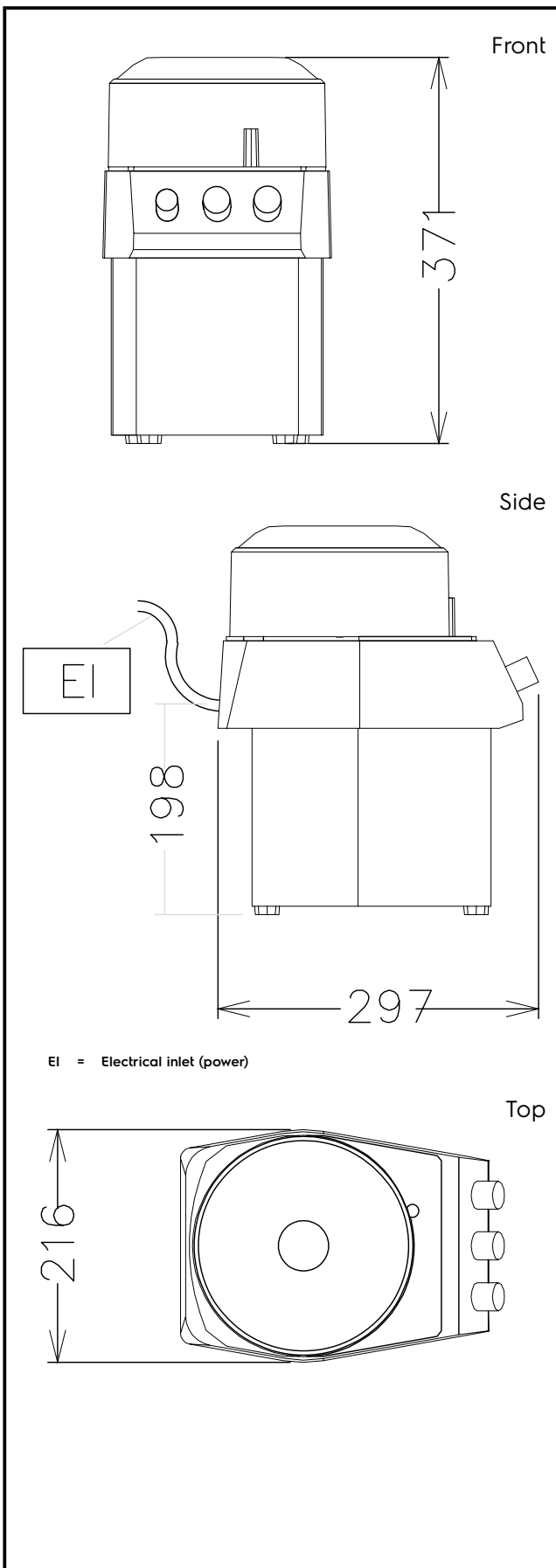
**Electric**

Supply voltage:	220-240 V/1N ph/50 Hz
603836 (K25Y)	
Electrical power max.:	0.37 kW
Total Watts:	0.37 kW

**Capacity:**

Performance (up to):	1 - kg/Cycle
Capacity:	2.5 litres

**Key Information:**

External dimensions, Width:	216 mm
External dimensions, Height:	371 mm
External dimensions, Depth:	297 mm
Shipping weight:	14 kg
Meat mincing capacity:	0.8 kg
Mayonnaise preparation capacity:	1 kg
Pastry preparation capacity:	1.3 kg